



THE KENTUCKY LOGJAM

PROVIDING ENVIRONMENTAL, SAFETY, AND PROFESSIONAL INFORMATION TO
KENTUCKY'S TIMBER HARVESTING OPERATORS

Editor, Jeffrey W. Stringer
Department of Forestry, University of Kentucky

Fall 2001

Volume 6 No. 4

Keeping Your Master Logger Status

The Kentucky Forest Conservation Act states that all Kentucky Master Loggers must complete six hours of continuing education in order to renew their Master Logger status beyond the expiration date listed on their KML Card. Continuing education is important not only because it is needed for maintaining your KML status, but it is one way to stay current on innovations, new regulations, best management practices and other topics related to timber harvesting. It's vital that Master Loggers understand the concept of continuing education and what is to be required of them. Therefore, I would like to try to answer some of the more common questions from Master Loggers about continuing education requirements.

What are continuing education units?

Continuing education units (CEUs) are what we refer to when recording your hours of continuing education. One instructional hour of continuing education equals one CEU. To renew your master logger designation you will need six hours of continuing education or six CEUs.

Who keeps track of your CEUs?

You are responsible for keeping track of your CEUs. In addition, the Master Logger office will keep track of your continuing education as best as possible. When you attend a KML pre-approved continuing education program, you will be required to fill out a Master Logger Sign-In Sheet at the beginning of the program. These sheets will be collected by the program provider and returned to KML office, where we can record the information. You will also be given a Kentucky Master Logger Designation Renewal Form (Form KML-5), which will enable you to keep track of your own CEU credits. Once you have achieved the six hours, you can submit this form to the Master Logger Office along with the renewal fee to renew your KML designation.

Can I obtain credit for courses that are not pre-approved by the Master Logger Office?

The answer is yes, as long as the course is taught by qualified individuals and falls within one or more of the following topics:

- *Forest Management *Silviculture
- *Forest Health *Ecosystem Management
- *Timber Harvesting *Logging Safety
- *Advanced Best Management Practices
- *Laws and Regulations relating to timber harvesting and water quality.

To obtain credit for the course you must fill out and submit a Continuing Education Unit Credit Form (Form KML-1). This form is available from the Master Logger Office and in the near future, will be on our web site at www.masterlogger.org.

How do I find out about upcoming continuing education programs?

This newsletter will contain information on when and where continuing education programs will be held. In addition, you can check with the Master Logger Office, the Kentucky Division of Forestry, the Kentucky Forest Industries Association, county Extension agents, and with local industry. The Master Logger Office will also send out notices of upcoming con-

Continued on page6



**Forest Roads and Design CEU class
at Trus-Joist July 2001**

Portable Skidder Bridges

May Keep You Out of Troubled Waters by Amy Thompson and Jeff Stringer



A low cost portable skidder bridge in Eastern Kentucky

Kentucky has over 89,431 miles of rivers and streams and over 637,000 acres of wetlands. In fact, in 1998 when a number of logging jobs were surveyed as part of BMP study, over 93% of them had some type of stream or drainage channel present. These numbers indicate that the odds of you having to cross a stream or channel on your next logging job are quite high.

Improper stream crossings can be a major source of sediment and disturbance to streams during timber harvests. To avoid excessive sediment deposits in streams, you should keep the number of stream and channel crossings to a minimum and cross using appropriate techniques.

Compliance with the Kentucky Forest Conservation Act requires that you use or install bridges or culverts to cross streams (perennial or intermittent) or ephemeral channels where feasible. While both bridges and culverts allow crossing with a minimal amount of stream impact compared to unimproved crossing, bridges are generally considered the best option from an environmental standpoint. This article will give you information on a safe, environmentally effective and affordable option for stream crossings, portable bridges.

Why Should You Consider Using a Portable Bridge?

There are a number of advantages to using portable bridges. These bridges can be easily removed and transported from site to site, resulting in savings of time and money with repeated use when compared to culverts or log stringer bridges that are built on site. You may be thinking that installing a bridge is a hassle you don't want to have to deal with on your logging job, but you may find it easier than you think. Loggers from North Carolina

reported that these types of bridges were more convenient to install than culverts or bridges built on site.

So What Exactly is a Portable Bridge?

Portable bridges for skidding can be made using a wide array of materials and techniques, including welding bridges from pipe, using old railroad cars or converting army surplus bridges for use in skidding operations. However, most common types of portable bridges are made from wood. There are many different styles and names of portable wooden bridges including dragline mats, crane mats, skidder mats, bridge mats, skidder bridges, timber bridges, solid sawn stringer bridges, and portable glulam panel bridges. The construction materials for these bridges can range from simple cants, to high-tech engineered lumber. All of the bridges, no matter their name or construction materials, have the same general design. Typically they consist of 2 or 3 fabricated panels placed side by side to form a bridge.

3 bridge panels placed side by side

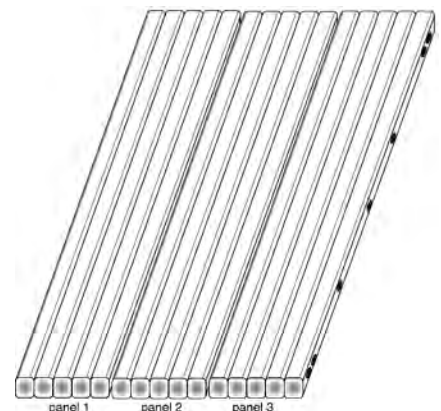

When constructed in the simplest form, the bridge panels are made from hardwood cants, fastened together with threaded rods. The panels are generally 4-6' wide, 8-10" thick and 16-32' long. The size you choose would depend on the width of the stream crossings you are likely to encounter, the size and type of your equipment and the load you need the bridge to support. In general the longer

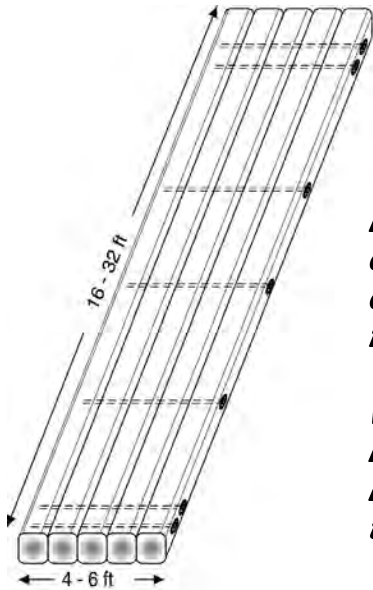

Diagram of a low cost panel constructed from five 10" cants. Threaded rods with countersunk nuts are used to hold the cants together

the panel the better; however you also need to take into account weight and ease of transport. Bridges are also available which are made from engineered lumber such as stress-laminated, glue-laminated, or dowel-laminated. Both the engineered lumber bridges as well as the cant bridges are available from commercial vendors. All bridges vary in cost, ease of installation, and durability. If you are planning on investing in one of these bridges, you need to carefully consider which type of bridge will best suit your needs. When selecting a bridge it is important to understand the bridge's limitations and work within those limits.

Bridge Placement and Getting Permits

All portable bridges should be installed on stream crossing sites that are flat, straight, and stable as possible. Be aware that if you are installing culverts or bridges, even portable ones, across a stream that drains over 1 square mile (640 acres), you will need to obtain a permit from the Kentucky Division of Water (contact them at 502-564-3410). If possible, choose a crossing location where the stream banks are well defined and the stream is running a relatively straight course. Finding a site with these characteristics will help ensure a smooth crossing,

keep the load on the bridge, and will reduce the amount of muddy water entering the stream. If the bridge panels are placed on uneven ground, there will likely be gaps between the panels that will allow sediment to fall into the stream. Generally panels can be used on stable stream banks and solid soils without any abutments or sills; the panels should extend 4 to 6 feet onto each side of the stream bank to provide support. Some site work may need to be completed before the bridge panels can be installed. Where possible the panels should rest about 3' above the stream bank; this will reduce the possibility of the bridge being washed away during a storm. However,



Dozer aligning bridge panels across an intermittent stream in Eastern Kentucky

if the bridge is only going to be in place for a short time, it may be possible to install the bridge closer to the stream. Normally the weight of the panels are enough to hold them in place; if there is concern about movement of the panels they can be fastened together or to other support structures. Having enough room to turn onto the bridge from the skid trail, and leaving bumper trees are good ways to make sure your load makes it onto and across the bridge. Installing some type of surfacing material such as crushed rock on the approaches can reduce the potential for sediment being washed into the stream, and increases traction. On relatively flat ground, water diversion structures such as turnouts or wing ditches should be installed on either side of the stream to prevent drainage

from the trail entering directly into the stream. When skidding on steeply sloping ground, do not run the trail directly down the hill onto the bridge. Plan the trail so that a gentle turn can be placed in the trail prior to the approach; this will allow water to be easily shed off the trail before turning onto the approach.

Skidder bridge installation and water control structures

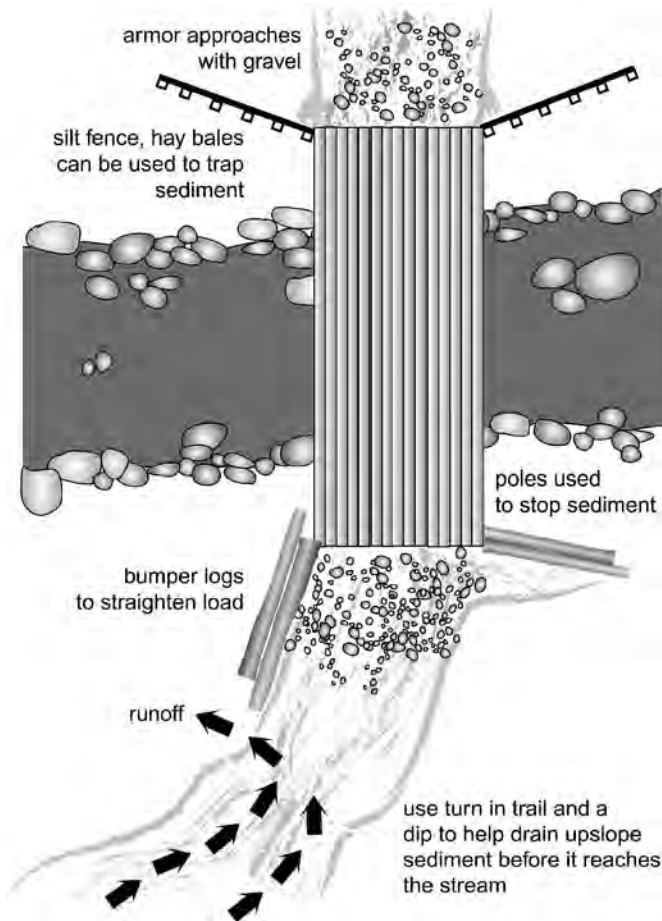

Bridge installation

Bridge panels are installed one at a time. They can be lifted into place with a knuckleboom loader, backhoe, or winched into place with a skidder or dozer. Grapple skidders can drag bridge panels to stream crossing site, turn around and, using their grapples, pick the panels up and set them across the stream. With a grapple skidder installation time can take as little as 30 minutes. A cable or chain and a dozer blade can also be used to lift a panel and set it across a stream. The blade is pushed against one end of a panel and a cable attached from the top of the blade to the other end of the panel. When the blade is raised the cable tightens and lifts the panel. While the bridge can be sloped along its length it is very important that it is level across its width; this is important not only for prevention of water pollution but also for the skidder operator's safety. As a last step, cull logs or cants can be placed on each side of the bridge to act as bumpers.

Portable bridge with bumper logs

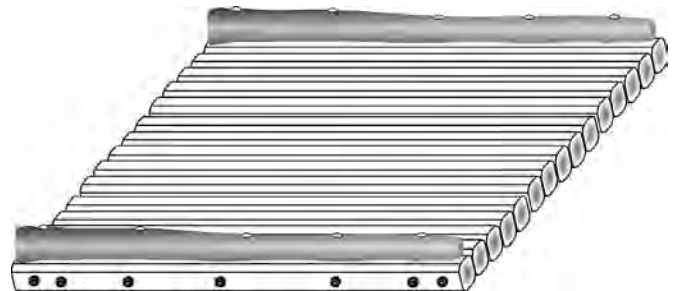

Use and Maintenance

Bridges need to be checked frequently for areas of weakness or excessive wear. You should also frequently check to make sure that the bridge panels have not separated; this would not only be unsafe but could also contribute to increased sediment entering the channel.



Bridge Panels should extend 4-6 feet on each side of the stream bank for support.

Retirement

Streambanks may need to be stabilized after removal. Seeding and mulching the disturbed ground will usually reduce the amount of sediment that enters the stream. The water diversion structures such as wing ditches or turnouts, which were installed during bridge placement, should be left in place to prevent runoff from going directly into the channel.

Removal and Transport

After the crossing is no longer needed, the bridge panels can be removed in the reverse order of installation. Before removal, dirt should be cleaned off the bridge surface so that sediment is not dumped into the channel.

List of Vendors

Listed below are sources of portable bridges. This listing was developed from information sent to the LogJam and obtained through a search of the Internet and does not indicate an endorsement by the authors, the Kentucky LogJam, or the University of Kentucky Cooperative Extension Service. It is provided solely as a service to the reader. If you know of other vendors, please contact the KML office at 1-800-859-6006. 

Geary Brothers, Inc.
Livermore, KY
(270) 278-2700

All-Star Forest Products
Gulfport, MS
(228) 896-4117

Hopewell Hardwood Sales
Hopewell, VA
(804) 458-5178

Charles Bates
Gretna, VA
(804) 656-6684 Evenings

Carolina Mat Company
Plymouth, NC
(800) 624-6027

American Mat and Timber
Baton Rouge, LA
(800) 671-0694

Johnson Lumber Co., Inc.
Easton, MD
(410) 822-5476

Hanna Mats
Winnfield, LA
(800) 336-3950

Building Your Own Portable Bridge

If you choose to build your own portable bridge, one of the most easily constructed designs involves the fastening together of 8" x 8" x 24' cants made from local timber. While heavier species such as oak will last longer, lighter species are generally preferred to aid in transportation and placement. Below are the general instructions for construction of a bridge panel fastened together with five threaded, high-tensile rods.

- 1) Square cants to proper length
- 2) Lay out cants for drilling holes for threaded rods
- 3) Drill holes, which are 25% - 50% larger in diameter than the threaded rods; this will make assembly easier
- 4) The outer-most cants will need to be countersunk to accommodate the washer and nut that will hold the fastening rod.
- 5) Make sure that holes are drilled straight so that cants line up correctly
- 6) Line up cants, insert threaded rods, attach washers and nuts, tighten nuts
- 7) If there is excess rod sticking out of the panel, it should be cut or ground off
- 8) Check and tighten nuts frequently while panels are in use and always after transporting them to a new site.
- 9) Generally cable, chockers, or grapples from skidders can be used to move panels. However, metal plates can be attached to end of panels so that a chain can be attached. Also one or two of the cants can be shortened to expose rods for fastening a chain. 

Options for Attachment Equipment

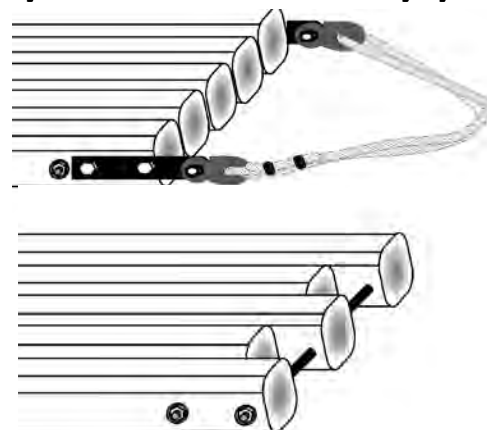

**If you lose your KML
card or move -contact
the KML Office!
1-800-859-6006**





Portable Bridge Loan Program

If you would like to use a portable skidder bridge but aren't quite ready to make the investment in buying one, you should contact the Kentucky Division of Forestry. The division has 18 bridges available for loan, free of charge, to loggers in Kentucky. Bridges will be loaned on a first-come, first-served basis and can be borrowed for up to 90 days. There are a few simple requirements for the bridge loan program. You will be required to leave a certified check or money order for \$500.00 that will be held, not cashed, as a deposit. If the bridge is returned to the division without excessive damage, the check or money order will be returned to you. You must sign an agreement releasing the state of any liability and have proof of insurance. You must notify the division where the bridge is going to be used. If you change jobs and move the bridge within the 90-day loan period, you must notify the division of the new location. Each Division of Forestry district has one 20-ft bridge and one 24-ft bridge available for loan. As winter weather approaches and logging conditions get wetter, a portable bridge borrowed from the Kentucky Division of Forestry would be a great help on your logging jobs to keep streams and channels free of sediment. Contact your local Kentucky Division of Forestry office or call 1-800-866-0555 for more information about the bridge project or to reserve bridge for your use. 



Portable bridge panels from the KDF loan program

KML Continuing Education Continued from page1
tinuing education programs when possible. Our Web site at www.masterlogger.org will soon have a schedule of known upcoming continuing education programs.

What happens if I do not get my six hours of continuing education before my card expires?

If your Master Logger Card expires and you have not obtained the six hours of continuing education, then your name will be removed from the active master logger list and if you harvest timber, you will be operating in violation of the Kentucky Forest Conservation Act. At this point you will have to repeat the three-day Master Logger Program in order to regain your Master Logger Designation.

Continuing education is a very important aspect of many professions in today's society. To stay competitive and successful within this industry, one must stay current on new developments related to our profession. Above are some of the more important questions that deal with the continuing education aspect of the Kentucky Forest Conservation Act. If you have additional questions or concerns regarding continuing education, then contact the KML office at 1-800-859-6006 or 859-257-6230. You can also email questions to kml@ca.uky.edu or refer to the continuing education section of our Web site at www.masterlogger.org. 

Mark Schuster, is coordinator of the Kentucky Master Logger Program and a forestry program specialist for the Kentucky Division of Forestry. When not on the road for the program, he works out of the KML office at the University of Kentucky



Remember:

After you have accumulated 6 CEU credits you need renew your Kentucky Master Logger Card. Call the Master Logger office for a renewal form.

KML 3-Day Program Schedule

2002

February 5, 14, 21 **Hardin Co.**
 Elizabethtown - Cooperative Extension Service Office

March 5, 13, 20 **Breathitt Co.**
 Jackson/Clayhole - UK's Robinson Forest

April 9, 17, 24 **Graves Co.**
 Mayfield - Cooperative Extension Service Office

April 10, 16, 23 **Hopkins Co.**
 Dawson Springs - Pennyriple State Resort Park

May 9, 15, 22 **Bell Co.**
 Pineville - Pine Mountain State Resort Park

September 11, 18 25 **Pulaski Co.**
 Somerset - Cooperative Extension Service Office

November 6, 13, 20 **Carter Co.**
 Olive Hill - Carter Caves State Resort Park

Kentucky BMP Logging Gauge Order One from the KML Office

The gauge is being offered through the mail at **\$6.00 (including shipping and handling)** through the Kentucky Master Logger Office. The gauge has been approved by the KDF and is a great help on getting started with BMPs.

Fill out the following:

Name _____

Street _____

City _____ State _____

Zip _____

Phone Number _____ - _____

Quantity (_____) x \$6.00 = \$_____

Make check payable to: Kentucky Master Logger Mail to:

Kentucky Master Logger Office
 UK Department of Forestry
 213 T. P. Cooper Building
 Lexington, KY 40546-0073

KML Logger Hotline 1-800-859-6006

KML Registration Form



Registration Form Kentucky Master Logger Program

Registration requirements:

1. All spaces must be completed.
2. Print or type.
3. A registration fee must be included.
4. Thoroughly review Program Information Section.
5. Only one participant per registration form (photocopies accepted).

Primary Occupation (check one)

Logger Gov't Agency _____

Other _____

Name _____
Last First M.I.

Mailing Address _____
Street Number (i.e., P.O. Box, Rural Route, etc.)

City _____ State _____ Zip Code _____

Phone number _____
(where participant can be reached during the day)

County of residence _____

Training Location

First Choice _____ Dates _____

Second Choice _____ Dates _____

REGISTRATION FEE: \$50.00 per person
 Make checks payable to: *Kentucky Master Logger*

Important Program Information:

- a) Registration fee is nonrefundable within five (5) days prior to the first day of training. Participants will be prioritized for class space up to five (5) working days before the class.
- b) If a participant cancels within five (5) working days or misses a session, he/she will be put on a waiting list for the next available training.
- c) The participant must provide personal transportation to field sites, as required at some locations.
- d) The participant must furnish personal protective equipment (PPE) hard hat, etc. Under no circumstances will participants be allowed onto field sites without proper personal protective equipment.
- e) Classes are limited to fifty (50) participants; the Commonwealth of Kentucky reserves the right to cancel a program if there are not sufficient participants scheduled at a location.
- f) Attendance of all three (3) sessions is required for graduation. However, a current First Aid and Adult CPR certification card can be substituted for attendance of First Aid and CPR Session.

Mail check with completed registration form to:

Kentucky Master Logger
 UK Department of Forestry
 213 T.P. Cooper Building
 Lexington, KY 40546-0073

THE KENTUCKY LOGJAM

NEWSLETTER
College of Agriculture
University of Kentucky
205 Thomas Poe Cooper Building
Lexington, Kentucky 40546-0073
RETURN POSTAGE GUARANTEED
ADDRESS SERVICE REQUESTED

INSIDE THIS ISSUE...

- **Keeping Your KML Status1**
- **Portable Skidder Bridges.....2**
- **Building A Portable Bridge.....5**
- **Portable Bridge Loan Program....6**
- **2002 Schedule for 3-Day KML.....7**

Kentucky LogJam Editor

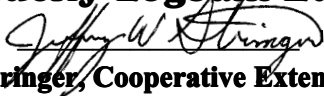

Jeffrey W. Stringer, Cooperative Extension Forester



3 Ways to Contact the Master Logger Office

- 1. Logger Hotline: 1-800-859-6006**
- 2. On the World Wide Web at:
www.masterlogger.org**
- 3. E-Mail: kml@ca.uky.edu**

The production of the Kentucky LogJam Newsletter is partially supported by Federal Section 319(h) Nonpoint Source Funds through the **Kentucky Division of Water's Nonpoint Source Section** and with funds from the Cooperative Extension Service at the University of Kentucky Department of Forestry.